

REMINGTON FIELD SERVICE MANUAL

The Remington Models 510-X, 511-X, 512-X are 22 Caliber, rim fire rifles of bolt action type. Short, Long, Long Rifle cartridges can be used interchangeably without action adjustment in all three models.

The Model 510-X is single shot and supplied in Smooth Bore (SB) grade. The Model 511-X is a repeater with clip magazine. Extra clips are available in 6 or 10 capacity. The model 512-X is also a repeater of tubular magazine type.

All three models have receivers grooved for tip-off type of sight mounts.

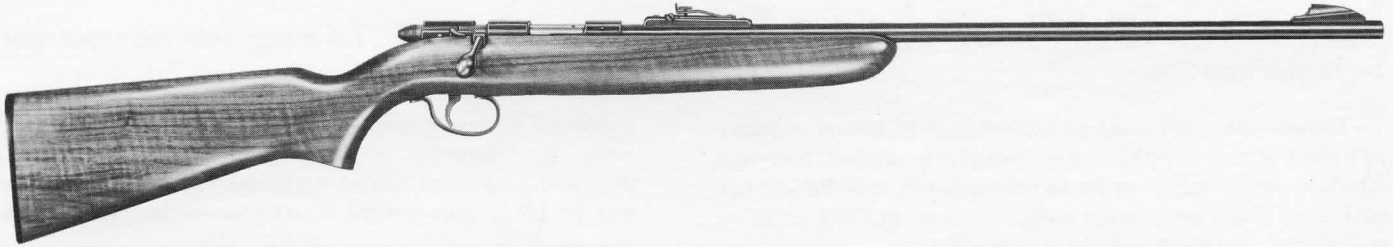

MODEL 510-X

Please package carefully if rifle is returned for factory service. Make sure all live ammunition is removed.

INDEX

	Page		Page
Bolt Assembly	1	Magazine Lock (511-X only)	3
Bolt Assembly — Components	1	Ejector (511-X only)	3
Front Sight	1	Receiver Insert, Rear (511-X only)	3
Rear Sight Assembly Complete	2	Cartridge Stop, Carrier, Carrier Spacer Bushing	4
Stock Assembly	2	Carrier Tension Spring (512-X only)	4
Stock Assembly Components	2	Ejector (512-X only)	4
Barrel	2	Trigger Assembly	4
Receiver Insert (510-X, 512-X)	3	Ejector (510-X only)	4
Receiver Insert, Front (511-X)	3	Inner Magazine Tube Assembly (512-X only)	4
Cartridge Stop Plunger	3	Cycle of Operation	4
Cartridge Stop Plunger Screw	3	Malfunctions	6
Cartridge Stop Plunger Spring	3	Parts List	7
Safety Switch Lever; Safety Switch Screw		Exploded View	8
Safety Switch	3		

Send all guns for factory service and inquiries on service and parts to
REMINGTON ARMS COMPANY, INC.
 Arms Service Division
 Ilion, New York 13357

MODEL 510-X, 511-X & 512-X

NOTE: Unless otherwise described, all parts are interchangeable with no factory assembly required. A number of parts are used on all three models. These "common" parts are listed below: Bolt Assembly (and included parts), Front Sight (and related parts). Rear Sight (and related parts), Receiver, Receiver Insert Retaining Pin, Safety Switch Lever, Safety Switch Screw, Trigger Assembly (and related parts), Butt Plate (and screws), Take Down Screw Escutcheon (in Fore End), Trigger Guard (and screws).

BOLT ASSEMBLY

To Disassemble - Push safety switch forward to **FIRE** position. Raise bolt handle, pull trigger and pull bolt to rear and remove from rifle.

To Reassemble—Bolt must be cocked (safety switch indicator will show at rear of bolt). If bolt becomes uncocked, push bolt assembly into receiver as far as possible. Lift bolt handle and cock bolt. Then with safety switch forward in **FIRE** position, pull trigger to allow bolt to slide into rifle.

BOLT ASSEMBLY — COMPONENTS — include bolt, bolt handle assembly, bolt sleeve, bolt sleeve pin, extractor left, extractor right, extractor pin, extractor spring, firing pin assembly, firing pin cam pin, main spring, main spring plunger, safety indicator.

To Disassemble — Remove bolt assembly from rifle. Uncock bolt by turning bolt handle until firing pin cam pin moves to forward position (at base of handle). Red indicator at rear of bolt **will not** show when bolt is uncocked. Tap out bolt sleeve pin. **Caution:** Bolt sleeve is under tension from main spring. Remove bolt sleeve, main spring, safety indicator, Slide out and remove loosened main spring plunger from bolt. Push out firing pin cam pin and remove bolt handle assembly from bolt. Push out firing pin cam pin and remove bolt handle assembly from bolt. Slide loosened firing pin assembly from bolt.

NOTE: Bolt Handle assembly includes bolt handle and cocking cam. Replace as assembly. Also, Firing Pin Assembly should be replaced as assembly. Assembly includes firing pin and firing pin point.

To Reassemble — Follow reverse order. Make sure main spring plunger aligns properly to bolt sleeve pin hole as bolt sleeve pin is reassembled. See Fig. 1.

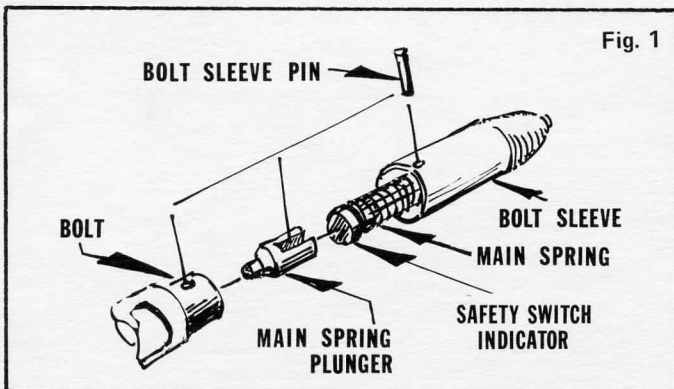

EXTRACTOR (2) and Parts

NOTE: Not necessary to disassemble any other bolt parts.

To Disassemble — Remove bolt assembly from rifle. Drive out both extractor pins. Remove extractor, right and extractor, left. Remove underlying extractor spring. This single spring supplies tension for both extractors.

To Reassemble — Insert extractor spring. Make sure extractor, right is placed in right side of bolt (towards handle).

NOTE: Extractor, right, has sharper right angle claw than extractor, left.

Assemble both extractors against tension of extractor spring, Hold, and assemble extractor pins. See Fig. 2. Drive and assemble pins from top of bolt. Make sure extractor pins do not protrude into double insert channel in bottom of bolt.

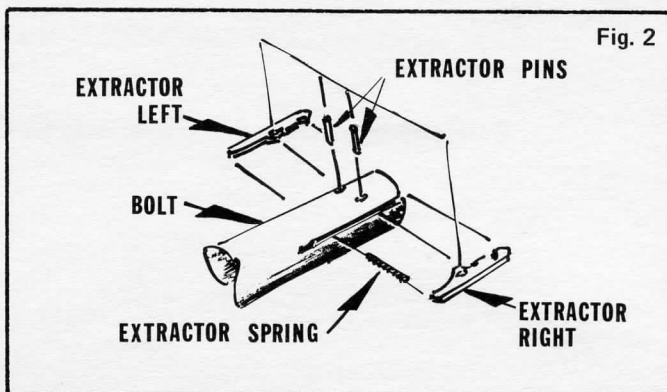

NOTE: Check reassembled extractors for proper tension using fired or spent cartridge cases.

BOLT

To Disassemble — Remove bolt assembly. Disassemble and remove all components as previously listed.

To Reassemble — See preceding components reassembly, instructions for bolt assembly.

FRONT SIGHT — is a "fixed type", not adjustable, and attached to barrel by two (2) screws.

To Disassemble — Unscrew front sight screw (2). Lift front sight from barrel. Take care that small nylon front sight washer (2) underlying screw heads are not lost.

To Reassemble — Locate properly on barrel radius and tighten firmly to barrel with sight screws.

NOTE: A threaded shotgun bead type is assembled to 510-X Smooth Bore (SB) model. No rear sight is used.

REAR SIGHT ASSEMBLY COMPLETE

To Disassemble — Unscrew and remove rear sight screw, front. Unscrew and remove rear sight screw, rear (longest). Lift and remove rear sight assembly, complete, from barrel.

To Replace— Interchangeable as complete assembly of rear sight assembly (which includes rear sight, elevation screw, elevation screw washer, rear sight plate, rear sight rivet, and windage screw.)

NOTE: Rear sight assembly or windage screw may be replaced separately if replacement rear sight rivet is used.

To Reassemble— Locate and align rear sight base to screw holes in barrel. Reassemble rear sight base screws and tighten sight securely to barrel.

Sight Adjustment— Turn elevation screw clockwise to raise sight. This will lift bullet impact on target or increase range. Turn windage screw clockwise to move sight to right. This will move bullet impact at target to right.

STOCK ASSEMBLY— includes stock, butt plate, butt plate screw (2), trigger guard, trigger guard screw (2), takedown screw, takedown screw escutcheon (in wood), and magazine guide plate, magazine guide plate screw if for Model 511-X.

To Disassemble— Unscrew and disassemble takedown screw. **NOTE:** Not necessary to remove screw completely from stock unless for replacement.

Takedown screw same for 510-X and 512-X. Remove stock assembly from receiver and barrel assembly (action).

NOTE: Remove clip magazine in 511-X before stock is disassembled. Extra 6 or 10 - shot clips are available. Each model requires own type of stock assembly.

To Reassemble— Follow reverse order. Tighten stock securely to action with takedown screw.

STOCK ASSEMBLY COMPONENTS

BUTT PLATE (and Screws)

To Disassemble— Unscrew butt plate screw (2). Remove butt plate.

To Replace— Interchangeable with no factory adjustment required. However, some edge removal may be needed to match butt plate to wood of stock.

To Reassemble— Locate butt plate to stock align holes, and tighten with reassembled butt plate screws (2).

TRIGGER GUARD (and screws)

To Disassemble— Unscrew trigger guard screw (2). Remove trigger guard.

To Reassemble— Follow reverse order.

TAKEDOWN SCREW - TAKEDOWN SCREW ESCUTCHEON is designed to provide a metal seat for takedown screw head. Serves also to hold takedown screw in stock when stock is removed from action.

To Disassemble — Loosen takedown screw and remove stock assembly from action. Pull takedown screw and turn until screw will release from takedown screw escutcheon in stock. Remove takedown screw. Tap against escutcheon from inner receiver cut in stock. Continue until knurled escutcheon is released from stock.

To Replace— Takedown screw is same for 510-X and 512-X. However, a tapered head screw with slightly longer shank is used for 511-X. This holds magazine guide plate (at front) in place. However, threading is same for all three models.

Takedown screw escutcheon is same for all models. No factory adjustment required.

To Reassemble— Follow reverse order for both parts.

MAGAZINE GUIDE PLATE (and screw) is designed for use on 511-X only as magazine (clip) entry port.

To Disassemble— Remove magazine clip. Unscrew and remove takedown screw. **NOTE:** Stock will loosen. Unscrew and remove magazine guide plate screw at rear. Lift and remove magazine guide plate.

To Reassemble— Follow reverse order.

BARREL— is not designed as "takedown" in the normal sense of the word. Barrel is double-pinned to receiver and forms a solid frame type of action **NOTE:** Barrel is same for 510-X. Barrel for 512-X is also same except threaded for magazine ring and magazine tube support screw.

To Disassemble— Remove bolt assembly and stock assembly. Drive out receiver insert retaining pin (2). Tap receiver back to disassemble loosened barrel from receiver. Remove sights. Remove inner magazine tube assembly, magazine ring, magazine tube support screw also if 512-X barrel disassembly.

To Replace— Interchangeable with no factory adjustment required except use heading plug in cartridge chamber to establish proper head space limits between replacement barrel and assembled bolt.

Seat replacement barrel (undrilled) into receiver and back against assembled bolt. Use 22 Caliber heading plug. Secure barrel firmly back in proper headspace position with bolt. Drill thru aligned receiver and receiver insert holes and into barrel. Use drill No. 22 (.157"). See Fig. 3.

Drive in receiver insert retaining pin (2). Drive pins thru aligned holes to join barrel, receiver insert to receiver.

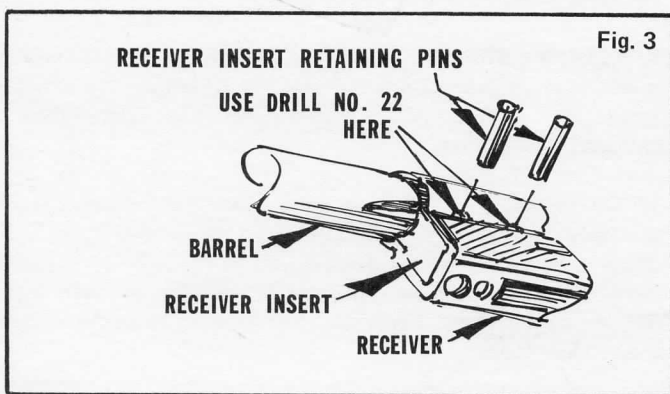

Fig. 3

To Reassemble – Follow reverse order. Realign all holes and drive in receiver insert retaining pins.

RECEIVER INSERT (510-X, 512-X)

RECEIVER INSERT, FRONT(511-X) – Inserts are designed to support barrel in receiver, to control bolt when closing, to aid cartridge loading in barrel, to control cartridge feeding.

NOTE: Receiver insert, front; includes receiver insert spacer, receiver insert spacer pin (at rear).

To Disassemble – Remove bolt assembly—and stock assembly. Remove barrel assembly. Tap loosened receiver insert forward and disassemble from receiver. For 512-X: Also unscrew small magazine screw at bottom front of receiver. Pull out outer magazine tube. Unscrew to remove cartridge retainer spring screw. See Fig. 4.

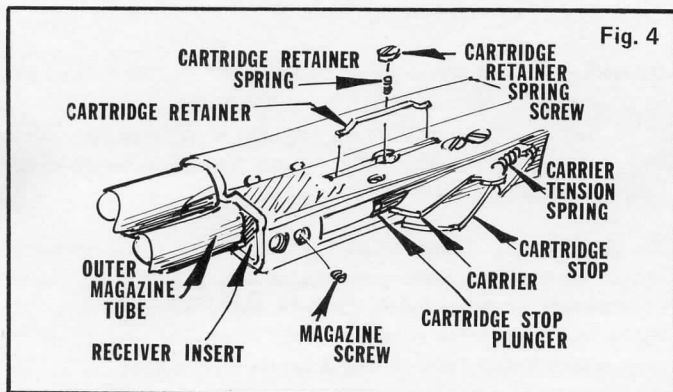

Fig. 4

Remove loosened cartridge retainer spring, cartridge retainer, Lower cartridge stop and carrier. See Fig.4. Tap receiver insert forward to disassemble.

CARTRIDGE STOP PLUNGER, CARTRIDGE STOP PLUNGER SCREW, CARTRIDGE STOP PLUNGER SPRING – are designed to control cartridge stop. (512-X).

To Disassemble – After receiver insert is removed, unscrew cartridge stop plunger screw (on left side of insert). Disassemble loosened cartridge stop plunger cartridge stop plunger spring.

To Replace – Interchangeable with no factory adjustment required. However, a new insert must be drilled with barrel in position. Reassemble barrel into receiver and realign receiver insert retaining pin holes in barrel and receiver. Tap in replacement receiver insert flush to front end of receiver. Use No. 22 size drill and drill insert thru realigned receiver and barrel pin holes. Drill in receiver insert retaining pin (2). Pins will join insert and barrel to receiver as solid assembly.

To Reassemble – Follow reverse order.

SAFETY SWITCH LEVER; SAFETY SWITCH SCREW; SAFETY SWITCH— is designed to restrict pull of trigger when safety switch lever is thumbed to rear stop – **ON SAFE** position. Red dot – **FIRE** position indicator is then covered by safety switch lever-not visible.

To Disassemble— Remove bolt assembly, and stock assembly. Unscrew and disassemble safety switch screw. Disassemble safety switch lever. Shake out and disassemble loosened safety switch.

To Replace— Interchangeable with no factory adjustment required. **NOTE:** Safety switch component for M/510 has higher shoulder to engage cocking cam on bolt. This engagement will occur as bolt assembly is withdrawn to open action. The safety switch then will be rotated by bolt assembly to **ON SAFE** position automatically as action is opened.

Safety switch component for 511-X and 512-X are same with no high shoulder as on 510-X.

To Reassemble— Make sure safety switch engages properly to trigger spring plunger. Seat safety switch lever properly also to keyway on reassembled safety switch as safety switch screw is tightened.

MAGAZINE LOCK (511-X only)

To Disassemble –Remove magazine clip and stock assembly. Unscrew and remove magazine lock screw. Disassemble magazine lock and magazine lock spacer from bottom of receiver insert, rear.

To Reassemble – Follow reverse order.

EJECTOR (511-X only)

RECEIVER INSERT, REAR (511-X only) – is designed to support magazine clip in position. Magazine lock components are screwed to bottom of insert. Receiver insert also provides spacer for sear and ejector when assembled.

To Disassemble – Remove bolt assembly and stock assembly. Remove magazine lock. Unscrew and remove sear pivot screw. Remove trigger pin. Unscrew and remove ejector screw (staked to receiver). Remove loosened ejector. Slide loosened insert forward in receiver. Remove loosened trigger assembly. Then slide insert back and disassemble from rear of receiver.

To Reassemble— Follow reverse order. See Note-Sear Pivot Screw **NOTE:** Trigger assembly should be inserted in receiver after receiver insert, rear, is placed **loosely forward** in receiver.

CARTRIDGE STOP, CARRIER, CARRIER SPACER BUSHING, CARRIER TENSION SPRING (512-X only)—are designed to control the feeding cartridge and halt the on coming next cartridge from magazine tube.

To Disassemble — Remove bolt assembly and stock assembly. Push carrier and cartridge stop downward to protrude from bottom of receiver. Unscrew and remove sear pivot screw. Disassemble loosened carrier and combined cartridge stop from bottom of receiver. **NOTE:** carrier spacer bushing and carrier tension spring will also disassemble — Take care.

To Reassemble — Join carrier to cartridge stop with carrier spacer bushing and carrier tension spring. See Fig. 5.

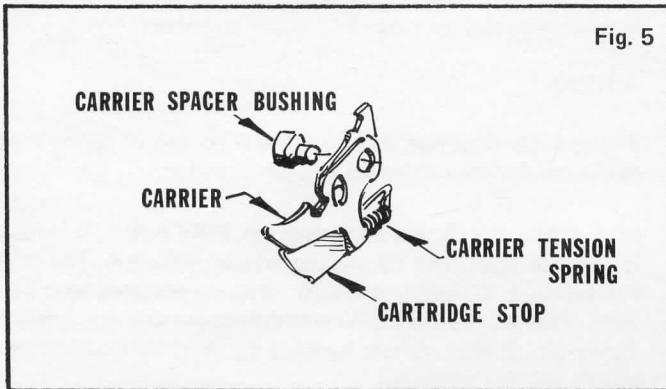

Hold parts together and reassemble to receiver. **NOTE:** When tightening sear pivot screw, **back screw** off to allow free play of carrier and cartridge stop in receiver. Then restake screw head in position

EJECTOR (512-X only) — is located to rear of receiver insert front; and to left side of receiver.

To Disassemble — Remove bolt assembly and stock assembly, Remove sear pivot screw, combined cartridge stop and carrier, ejector screw and ejector.

To Replace — Interchangeable with no factory adjustment required. **NOTE!** When replacing sear pivot screw, tighten only enough to allow free play of reassembled cartridge stop and carrier. Then restake screw head to hold position.

To Reassemble — Follow reverse order.

TRIGGER ASSEMBLY — Includes sear, sear stud and trigger. Related to this assembly is sear pivot screw, sear spacing collar, ejector, trigger pin, trigger spring, trigger spring plunger. Trigger spring plunger places safety switch under tension during trigger engagement.

To Disassemble — Remove bolt assembly and stock assembly. Remove safety switch. Remove loosened trigger spring plunger and spring.

510-X — Unscrew and remove sear pivot screw (staked to receiver). Disassemble loosened sear spacing collar. Drive out trigger pin. Push loosened trigger assembly upward into receiver, forward, and disassemble, sear first, thru bottom of receiver near receiver insert.

511-X — Unscrew and remove sear pivot screw (staked). Drive out trigger pin. Unscrew and remove ejector screw. Slide loosened receiver insert, rear and ejector forward in receiver. Push loosened trigger assembly upwards into receiver, forward, and disassemble, sear first, thru bottom of receiver near loosened receiver insert, rear.

512-X — Unscrew and remove sear pivot screw (staked). Remove loosened cartridge stop, carrier, carrier spacer bushing, carrier tension spring from receiver. Drive out trigger pin. Push loosened trigger assembly upward in receiver, then forward and down, sear first, from bottom of receiver.

To Reassemble — Follow reverse order for all models. When reassembling sear pivot screw tighten pivot screw then back off slightly to allow free play of sear on pivot screw. Restake head of pivot screw to outside of receiver to hold screw securely in position.

EJECTOR (510-X) — is threaded for ejector screw. Same ejector is used for Model 512-X. Ejector for 511-X is unthreaded.

To Disassemble — Remove bolt assembly, stock assembly, and sear pivot screw. Unscrew and remove ejector screw. Disassemble ejector.

To Reassemble — Follow reverse order. See adjustment and restaking of sear pivot screw.

INNER MAGAZINE TUBE ASSEMBLY (512-X only)—May be serviced by removing magazine pin after removal from rifle. However, replacement as assembly is recommended.

CYCLE OF OPERATION

The Remington Models 510-X, 511-X and 512-X are 22 caliber bolt action rifles. All three models are chambered for short, long or long rifle cartridges operating interchangeable without adjustment. A smooth bore (SB) 510-X is also available, shooting shot cartridges.

Two of these models, the 511-X and 512-X, are repeaters; that is, having a cartridge loading capacity. These models are equipped with different type magazines.

Model 511-X is furnished with a removable six shot clip type magazine. Extra clips including a ten shot are available.

Model 512-X has a tubular type magazine. Cartridges may be loaded interchangeable without adjustment.

MODEL 510-X, 511-X & 512-X

The remaining Model 510-X is a single shot rifle. One feature found only in the 510-X is automatic operation of the safety switch. In this model, complete rearward movement of bolt automatically places safety switch in **ON SAFE** position.

These three rifles are common to other bolt action rifles of this type. Because of similarity of these models the following cycle of operation has been grouped to cover all three rifles.

SAFETY SWITCH

Thumb operated safety switch lever is located at rear sight side of receiver in all three models. Rotation of safety switch rearward places rifle in **ON SAFE** position. Pushing safety switch forward places rifle in **FIRE** position. With safety switch pushed forward a red dot indicator will show on receiver behind safety switch lever. A red band marking at rear of bolt will also show when rifle (or bolt) is cocked.

UNLOCKING – COCKING – LOCKING

With each lifting, then lowering of bolt handle, three cycles take place.

UNLOCKING

Lifting of bolt handle upwards rotates locking lugs out of support with shoulders in receiver. With locking lugs in this position bolt is free to be drawn rearward.

COCKING

During unlocking, lifting bolt upwards also rotates cocking cam on bolt. Rotating cam draws firing pin rearward. Firing pin is held rearward by means of a dwell in cam. As bolt is lowered, cam rotates in opposite direction releasing hold on firing pin. Firing pin then moves forward slightly, latching against sear. Sear then holds firing pin rearward in cocked position, completing cycle.

LOCKING

Downward movement of bolt handle during cocking rotates locking lugs against supporting shoulders located in receiver.

FEEDING

Because of different feeding methods in each model, this phase of Cycle of Operation is broken down as follows:

Model 510-X — In this single shot action, feeding cycle is performed by placing cartridge on loading platform (receiver insert).

Model 511-X — Equipped with removable clip type magazine, cartridges are urged upwards into loading position by magazine spring.

Model 512-X — Having a tubular type magazine, cartridges are released and separated from magazine by cartridge stop. With bolt fully forward, carrier and cartridge stop are in a downward position allowing first cartridge to slide back over carrier. Movement of bolt rearward raises carrier, bringing cartridge upward into engaging position with bolt. At same time cartridge stop rises to intercept next cartridge in magazine column. As bolt is pushed forward during loading cycle, carrier and cartridge stop are pushed downward by bolt, releasing next cartridge in magazine column.

LOADING

Following feeding cycle, forward movement of bolt on all three models engages rim of cartridge. Continued forward travel of bolt carries cartridge into barrel chamber.

FIRING

Firing cycle on these three models is release of spring loaded firing pin forward to strike rim of cartridge.

With safety switch pushed forward in **FIRE** position, firing pin is released and fired by pulling trigger rearward. The trigger rotates as it is pulled rearward, drawing attached sear downward. This downward movement disengages sear and firing pin. Firing pin is then driven forward by recessed main spring to indent and fire cartridge.

EXTRACTION

In each of these models extraction or unloading of cartridges is done by pulling bolt rearward. As bolt is pulled back, two claw-like extractors located at head of bolt, grasp and pull cartridge from barrel.

EJECTION

Following extraction, continued movement of bolt carrier cartridge into contact with a stationary ejector. Engagement with ejector halts movement of cartridge. The cartridge then pivots on right extractor away from bolt and out of receiver opening. Pivot pressure from spring tension in extractor assists in ejection of cartridge.

For details on cleaning, care and operation of rifle see Instruction Folder for each rifle. List prices, and parts identification are also included in each folder.

MALFUNCTIONS

Cause and Correction

MISFIRES

Cause:

1. Firing pin protrusion short.
2. Firing pin damaged.
3. Damaged chamfer at rear of chamber.
4. Max. head space.
5. Faulty ammunition.
6. Trigger spring weak.
7. Trigger binds.
8. Damaged sear.
9. Sear notch damaged on firing pin.

Correction:

1. Replace firing pin.
2. Replace firing pin.
3. Replace new barrel
4. Replace new bolt.
5. Replace ammunition.
6. Replace spring.
7. Free up.
8. Replace sear.
9. Replace firing pin.

FAILS TO UNLOCK

Cause:

1. Damaged cocking cam.
2. Damaged cam pin.
3. Rough chamber (fouled, pitted).
4. Firing pin hits barrel— upsets chamber.
5. Safety switch indicator or main spring in bolt binds.

Correction:

1. Replace cam or bolt
2. Replace pin.
3. Ream or polish.
4. Ream chamber, correct firing pin protrusion.
5. Replace.

FAILS TO EXTRACT

Cause:

1. Rough, fouled, damaged chamber.
2. Extractor slots in barrel damaged.
3. Damaged extractor.
4. Incorrect hook space or tension on extractor.

Correction:

1. Ream if tight or rough. Replace barrel if oversize.
2. File to depth.
3. Replace extractor.
4. Adjust or replace extractor.

FAILS TO EJECT

Cause:

1. Incorrect hook space or tension on extractor.
2. Ejector damaged, missing, out of position.

Correction:

1. Adjust or replace.
2. Adjust or replace.

FAILS TO COCK

Cause:

1. Trigger spring weak.
2. Damaged sear notch.
3. Damaged sear notch on firing pin.
4. Damaged notch on sear or firing pin.
5. Damaged angle on sear or firing pin.
6. Trigger Binds.

Correction:

1. Replace spring.
2. Replace sear.
3. Replace firing pin.
4. Replace part.
5. Replace part.
6. Free up.

FAILS TO FEED (511—X only)

Cause:

1. Damaged magazine clip.
2. Damaged ears on magazine clip.
- 3; Follower binds.
4. Damaged chamfer on pick-up rail of bolt.

Correction:

1. Replace magazine clip or stock if necessary.
2. Adjust or replace magazine clip.
3. Replace magazine clip.
4. Change bolt.

FAILS TO FEED (512—X only)

Cause:

1. Receiver insert ears not properly placed.
2. Carrier binds.
3. Damaged chamfer on pick-up rail of bolt.
4. Damaged panel cut in receiver insert.
5. Cartridge retainer out of adjustment.
6. Cartridge retainer out of adjustment.
7. Inner magazine tube damaged or dented.
8. Magazine spring weak.
9. Carrier doesn't insert.
10. Feed hole in insert rough or restricted.

continued on pg. 9

View No.	NAME OF PART	View No.	NAME OF PART
1	Barrel (510-X)	40	Magazine Screw (512-X)
	Barrel (511-X)	41	Magazine Spring (512-X)
	Barrel (512-X)	42	Magazine Tube Support Screw (512-X)
2	Bolt	43	Main Spring
	Bolt Assembly (includes Bolt, Bolt Handle Assembly, Bolt Sleeve, Bolt Sleeve Pin, Extractor, Left; Extractor, Right; Extractor Pin, Extractor Spring, Firing Pin Assembly, Firing Pin Cam Pin, Main Spring, Main Spring Plunger, Safety Indicator)	44	Main Spring Plunger
3	Bolt Handle Assembly (includes Bolt Handle and Cocking Cam)	45	Outer Magazine Tube (512-X)
4	Bolt Sleeve	46	Rear Sight Assembly (includes Rear Sight, Elevation Screw, Elevation Screw Washer)
5	Bolt Sleeve Pin		Rear Sight Assembly, Complete (includes Rear Sight Assembly, Rear Sight Plate, Rear Sight Rivet, Windage Screw)
6	Butt Plate		Rear Sight Plate
7	Butt Plate Screw	47	Rear Sight Rivet
8	Carrier (512-X)	48	Rear Sight Screw, Front
9	Carrier Spacer Bushing (512-X)	49	Rear Sight Screw, Rear
10	Carrier Tension Spring (512-X)	50	Receiver (510-X and 511-X)
11	Cartridge Retainer (512-X)		Receiver (512-X)
12	Cartridge Retainer Spring (512-X)	51	Receiver Insert (510-X)
13	Cartridge Retainer Spring Screw (512-X)	52	Receiver Insert (512-X)
14	Cartridge Stop (512-X)	53	Receiver Insert, Front (511-X)
15	Cartridge Stop Plunger (512-X)	54	Receiver Insert, Rear (511-X)
16	Cartridge Stop Plunger Screw (512-X)		Receiver Insert Retaining Pin
17	Cartridge Stop Plunger Spring (512-X)		Receiver Insert Spacer
18	Ejector (510-X and 512-X)	55	Receiver Insert Spacer Pin
	Ejector (511-X)		Safety Switch (510-X)
19	Ejector Screw (510-X and 512-X)	56	Safety Switch (511-X and 512-X)
	Ejector Screw (511-X)	57	Safety Switch Indicator
20	Extractor, Left	58	Safety Switch Lever
21	Extractor, Right	59	Safety Switch Screw
22	Extractor Pin	60	Sear
23	Extractor Spring	61	Sear Pivot Screw
24	Firing Pin Assembly (includes Firing Pin and Firing Pin Point)	62	Sear Spacing Collar (510-X)
25	Firing Pin Cam Pin	63	Sear Stud
26	Front Sight		Stock Assembly (510-X) (includes Butt Plate, Butt Plate Screw (2), Stock, Take Down Screw Escutcheon, Take Down Screw, Trigger Guard, Trigger Guard Screw (2))
27	Front Sight Screw		Stock Assembly (511-X) (includes parts listed for 510-X Stock Assembly plus Magazine Guide Plate and Magazine Guide Plate Screw)
28	Front Sight Washer		Stock Assembly (512-X) (includes parts listed for 510-X)
29	Inner Magazine Tube (512-X)		Take Down Screw (510-X and 512-X)
	Inner Magazine Tube Assembly (512-X) (includes Inner Magazine Tube, Magazine Follower, Magazine Pin, Magazine Plug, Magazine Spring)	64	Take Down Screw (511-X)
30	Magazine Assembly (6 Shot) (511-X) (includes Magazine, Magazine Bottom, Magazine Follower, Magazine Spring)	65	Take Down Screw Escutcheon
	Magazine Assembly (10 Shot) (511-X)	66	Trigger
31	Magazine Follower (512-X)	67	Trigger Assembly (includes Sear, Sear Stud, Trigger)
32	Magazine Guide Plate (511-X)	68	Trigger Guard
33	Magazine Guide Plate Screw (511-X)	69	Trigger Guard Screw
34	Magazine Lock (511-X)	70	Trigger Pin
35	Magazine Lock Screw (511-X)	71	Trigger Spring
36	Magazine Lock Spacer (511-X)		Trigger Spring Plunger
37	Magazine Pin (512-X)		Windage Screw
38	Magazine Plug (512-X)		
39	Magazine Ring (512-X)		

MODEL 510-X, 511-X & 512-X

Correction:

1. Adjust ears.
2. Adjust cartridge stop or sear pivot screw.
3. Change bolt.
4. File corners of cut.
5. Adjust.
6. Adjust.
7. Replace tube.
8. Replace
9. Adjust cartridge stop.
10. Ream feed hole.

FAILS TO LOAD

Cause:

1. Excessive opening between ears of magazine clip (or receiver insert in M/512).
2. Extractors out of adjustment.
3. Damaged bolt.
4. Burr at edge of chamber.
5. Carrier binds (M/512 only).

Correction:

1. Adjust
2. Adjust or replace.
3. Fit new bolt.
4. Remove burr.
5. Free up.

FAILS TO LOCK

Cause:

1. See Bolt binds.
2. Damaged chamber (rough, pitted).

Correction:

1. See Bolt binds.
2. Replace barrel.

BOLT BINDS

Cause:

1. Sear catches on firing pin.
2. Ejector too high.
3. Receiver tight at bolt handle clearance.
4. Bolt damaged.
5. Bolt sleeve pin or ejector pin protruding.

Correction:

1. Smooth up rail of firing pin.
2. Adjust.
3. Adjust.
4. Replace bolt.
5. Re-position.

BOLT PULL OUT

Cause:

1. Sear binds.
2. Trigger binds.

3. Sear damaged.

4. Bolt damaged.

Correction:

1. Free up.
2. Free up.
3. Replace sear.
4. Replace bolt.

FIRE ON SAFE SAFETY SWITCH GOES ON AFTER FIRING (510-X, 511-X)

Cause:

1. Bent safety switch screw.
2. Damaged safety switch.
3. Trigger binds.

Correction:

1. Replace screw.
2. Replace safety switch.
3. Free up.

BULGES OR BLOWS CASES

Cause:

1. Chamber damaged.
2. Max. head space.
3. Damaged extractor slot in barrel.
4. Faulty ammunition.

Correction:

1. Replace barrel
2. Replace bolt.
3. Replace barrel.
4. Replace ammunition.

ACCURACY

Cause:

1. Crown of barrel damaged.
2. Bore leaded.
3. Damaged or rough bore.
4. Loose sights.

Correction:

1. Recrown.
2. Lead or change barrel.
3. Replace barrel.
4. Tighten.

POINT OF IMPACT

Cause:

1. Barrel not straight.
2. Improper or loose sights.

Correction:

1. Straighten.
2. Tighten, adjust, change sights.